



FP2019 QE20 Fan Cooling Module Installation Instructions

1. General Description

This sheet describes installation of the FP2019 QE20 Fan Cooling Module. The module may be fitted to an existing QE20 cabinet to provide forced air cooling when a system is expanded above the natural cooling limit, or as a replacement for an existing Fan Cooling Module.

The Fan Cooling Module is fitted into the top cap of the QE20 cabinet in the area above the 19" racking. It does not occupy any 19" rack space and can be added to an existing QE20. The two baffles included are mounted in the top and bottom inside of the cabinet outer door, and an air filter is mounted in the bottom of the cabinet. The general arrangement is shown in Figure 1.

The fan operates off 24V dc, is controlled by an output on the QE20, and is monitored by an input.

Replacement air filters may be purchased using part number FP2028. The FP2028 QE20 Air Filter Kit provides 5 replacement filters for installation in the QE20 Cabinet.

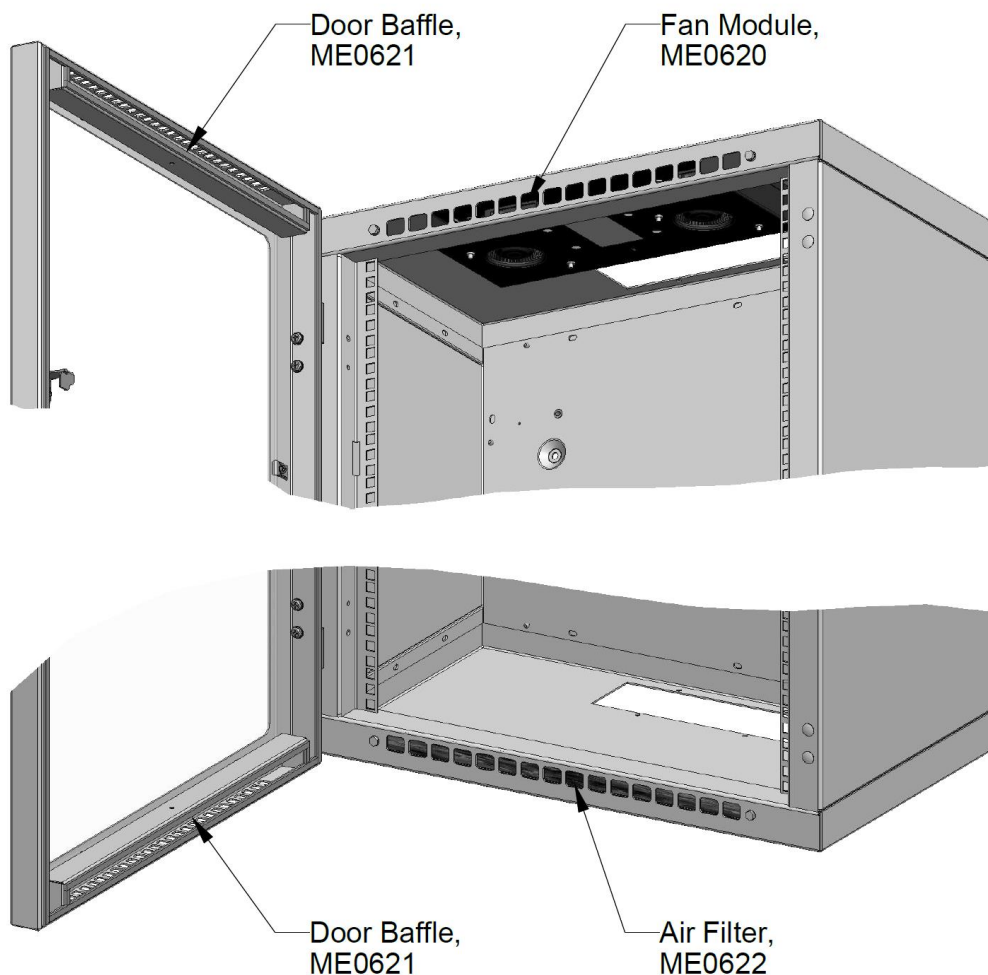

Figure 1 – FP2019 QE20 Fan Cooling Module Components in QE20 Cabinet

2. Kit Contents

Each kit contains:

- 1 x ME0620 Fan Cooling Module c/w leads to connect to 24V and input and output
- 2 x ME0621 Baffles for fitting to the top and bottom of the cabinet outer door
- 1 x ME0622 Air filter to fit to the bottom of the cabinet
- 4 x M5 x 10 Screws to secure the module and air filter into the cabinet
- 1 x LT0713, these installation instructions.

3. Mounting the Fan Cooling Module

Details for mounting the components of the Fan Cooling Module are shown in sheets 1 - 4 of drawing 1919-133 included in this guide.

Sheet 1 shows the general location of the components in the QE20 cabinet.

Sheet 2 details the mounting of the baffle in the inside top of the outer door. The second baffle is mounted in the bottom of the outer door in a similar manner.

Sheet 3 shows mounting of the Fan Cooling Module in the top cap of the cabinet.

Sheet 4 shows mounting of the air filter chassis in the bottom of the cabinet.

The cabinet should be mounted so that air can move freely in and out of the top and bottom of the cabinet outer door. These areas should be kept clear to not obstruct the airflow.

4. Replacing an Existing Module

When replacing a Fan Cooling Module unplug the 24V power loom and disconnect the three wires that extend from the Fan Cooling Module from where they terminate into the controlling output and monitoring input. Remove the fan module and fit the replacement. Connect the controlling wires and monitoring wire to the controlling output and monitoring input as before. Plug in the 24V power lead. Check all faults clear and that the fan operates when required.

There are no adjustments / settings needed in the module itself. The factory-supplied setup is sufficient.

5. Fitting a New Module

Mount the Fan Cooling Module as described in Section 3 and connect the wiring as per Section 6. Refer to the System Design and the site configuration for which inputs and outputs the fan module needs to be wired to.

Internal Configuration

No changes from the factory default settings are required.

6. Internal Wiring

The QE20 Fan Cooling Module requires the red and black power lead to be connected to a 24V dc output from a PSE.

The Fan Cooling Module provides a Control Input to make the fans run and a status output to indicate a fault.

- For the Fan Run Control input apply 24V between the red/white and black/blue pair of wires to make the fans run. This pair has a 2K7 load resistance, so a supervised VAD output or load supervision on a supervised open-collector output can be used to detect if the wiring is disconnected from the output.
- The green wire is the Status output. It presents 2k7 to the 0V connection of the 24V DC lead to the Fan Cooling Module when the Fan Cooling Module is powered up, both fans are connected and the fans are not running. It goes open when there is a fault or power is not applied to the Fan Cooling Module.

The general wiring arrangement is shown on drawing 1919-133 sheet 5 included in this guide. The controlling output and fault status input must match those assigned in the site configuration.

7. Field Wiring

There is no field wiring for the Fan Cooling Module.

8. LED Indications

Operation of the fans can be confirmed by the noise they make when running, or the flow of air being forced out of the exhaust grill at the top of the cabinet.

There are 5 LED indications inside the Fan Cooling Module. These are visible by looking through the centre slots of the exhaust grill at the top of the cabinet. The LEDs run from left to right with the green POWER LED on the right-hand side. If any yellow LED is on a fault is present.

LED Indicators (from LHS)

- **RUN FLT 1** : (LD1 Yellow) This turns on if fan #1 does not rotate when the fans are turned on.
- **LOAD FLT 1** : (LD2 Yellow) This turns on if fan #1 is shorted or disconnected from the control PCB.
- **RUN FLT 2** : (LD3 Yellow) This turns on if fan #2 does not rotate when the fans are turned on.
- **LOAD FLT 2** : (LD4 Yellow) This turns on if fan #2 is shorted or disconnected from the control PCB.
- **RUN** : (LD5 Green) Turns on when the RUN control input is activated to make the fans run.
- **POWER** : (LD6 Green) On when 24V power is applied to the fan control module.

The Fan Cooling Module will generate an open circuit condition (fault) on its Status Output if any of the internal fault indicators are on or if 24V power is not applied to the Fan Cooling Module.

9. Power On & Testing

Operation of the fans is automatic if the QE20 is programmed correctly. If a zone is allocated to the fan status, then activating Evac on this zone will turn the fans on for test purposes. Pressing Evac if it is on will turn the fans off if all the zones are no longer active.

10. Fan Cooling Module Specifications

Power Requirements	18V – 32Vdc, 10 ma quiescent, 1700 mA typ @ 26V both fans running
Operating Conditions	-5°C to +45°C 10% to 93% RH non-condensing
RUN Control Input	Apply 24V (>12V) @ 20mA between Red/White and Black/Blue wires to make the run fans. 2K7 internal resistance.
Status Output	2K7 to 0V - Normal. Open circuit - Internal fault (RUN or LOAD faults) or no 24V power Short circuit - RUN active and J8 1 – 2 linked.

ITEM	PART NO.	QTY	DESCRIPTION
1	ME0620	1	ME, 1919-130, QE20 RACK CAB FAN MODULE
2	ME0621	2	ME, 1919-131, QE20 RACK CAB OUTER DOOR BAFFLE
3	ME0622	1	ME, 1919-132, QE20 RACK CAB AIR FILTER

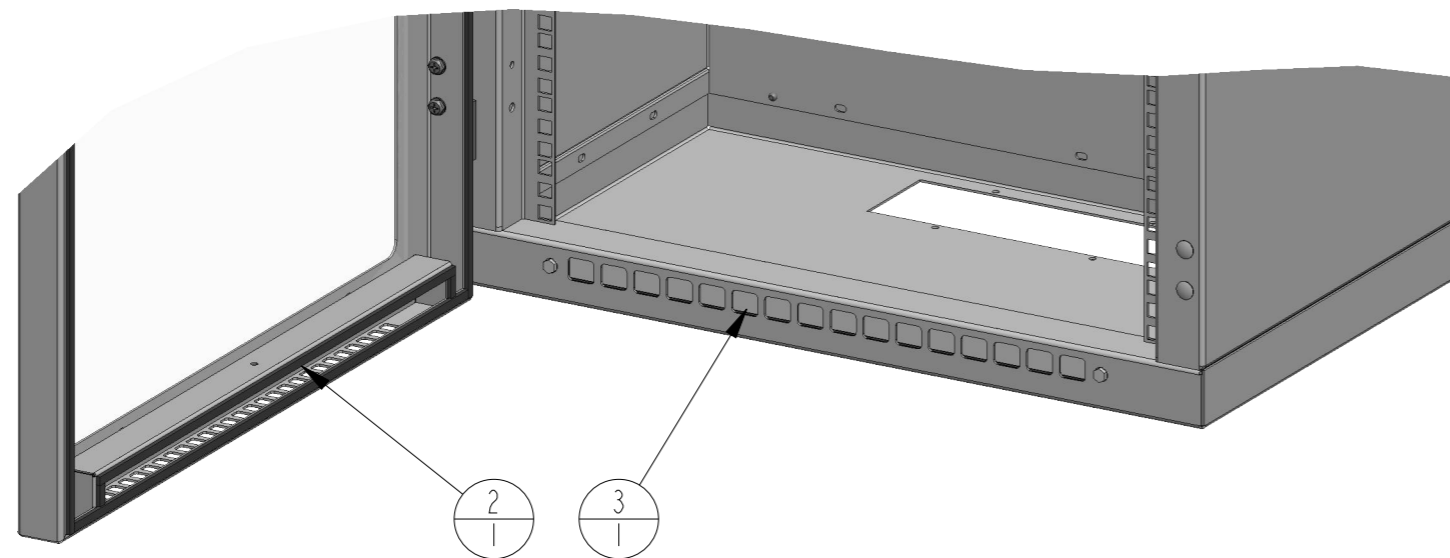
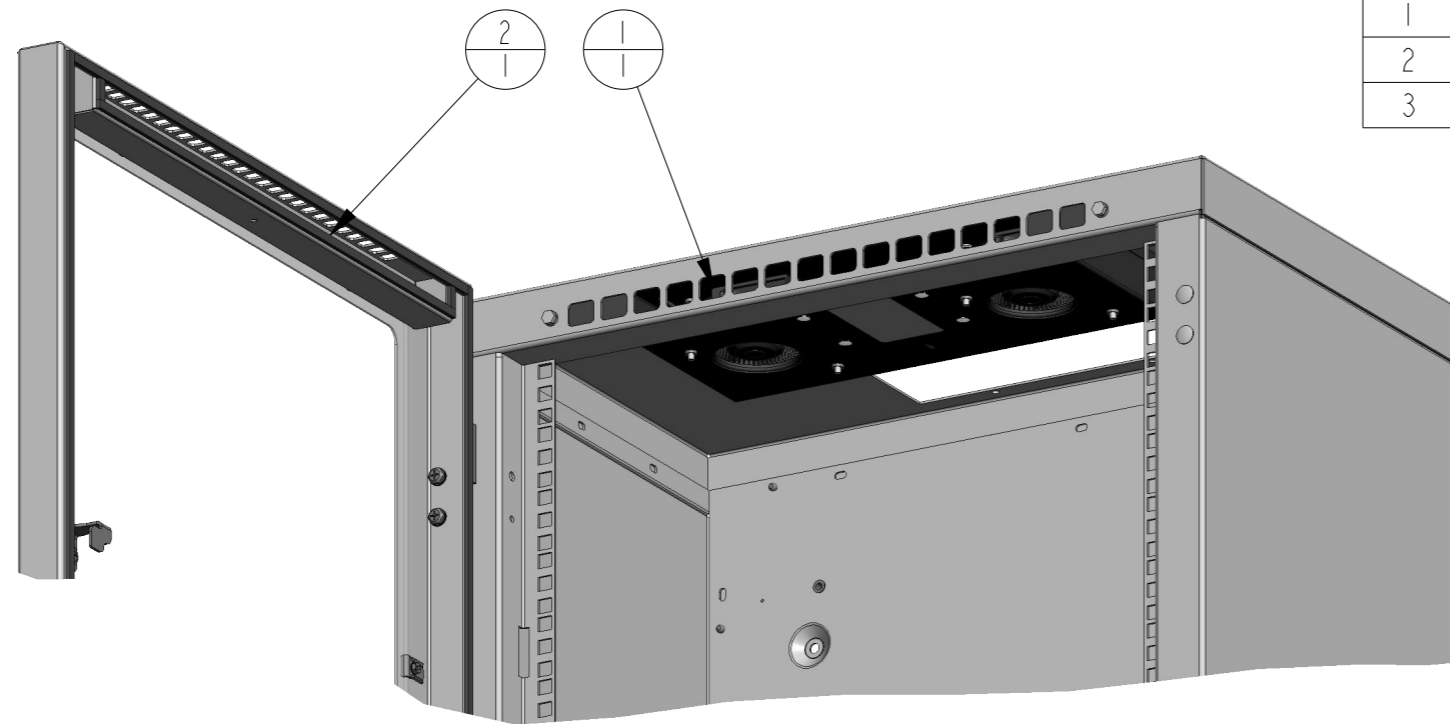

PART VIEW SHOWING COOLING MODULES
MOUNTED IN CABINET
SCALE 0.200

NOTES:
1. REFER TO SHEETS 2, 3 & 4 FOR MODULE MOUNTING DETAILS.
2. REFER TO SHEET 5 FOR COOLING MODULE WIRING DETAILS.

CONFIDENTIAL THIS DOCUMENT MUST NOT BE COPIED NOR THE CONTENTS PASSED ON TO ANY THIRD PARTY WITHOUT THE CONSENT OF THE COMPANY.

UNLESS OTHERWISE STATED: ALL DIMENSIONS IN MILLIMETRES. DO NOT SCALE. TOLERANCES ARE TO BE: 1 DECIMAL PLACE ±0.5, 2 DECIMAL PLACES ±0.3, 3 DECIMAL PLACES ±0.1

3rd ANGLE PROJECTION

ISS/REV	AMENDMENTS	ECO	DRN	CHKD	AUTH	APVD	DATE
A	ORIGINAL	5245	KJS	LSC	MH	DC	02-12-19

© 2019 Johnson Controls. All rights reserved. All specifications and other information shown were current as of document revision date and are subject to change without notice.

JOHNSON CONTROLS
17 MARY MULLER DRIVE
P.O. BOX 19545
CHRISTCHURCH, PH: +64 3 3895096
NEW ZEALAND. FAX: +64 3 3895938

QE20 CABINET COOLING RACK CAB COOLING MODULES MOUNTING DETAILS		
DRAWING No: 1919-133		SHEET 1 of 5
A3	ISS/REV A	PART No: ME0623

ITEM	PART NO.	QTY	DESCRIPTION
1	FA1163	4	FAB, BARREL NUT, M4 X 14mm, 7mm MAX A/F, STEEL, ZP
2	NT0009	4	NUT, HEX, MACHINE, M4, ZP
3	WA0006	4	WASHER, FLAT, M4 ZP 9MM OD IMM THICK
4	WA0011	4	WASHER, SHAKEPROOF, M4 I.T LOCK, ZP

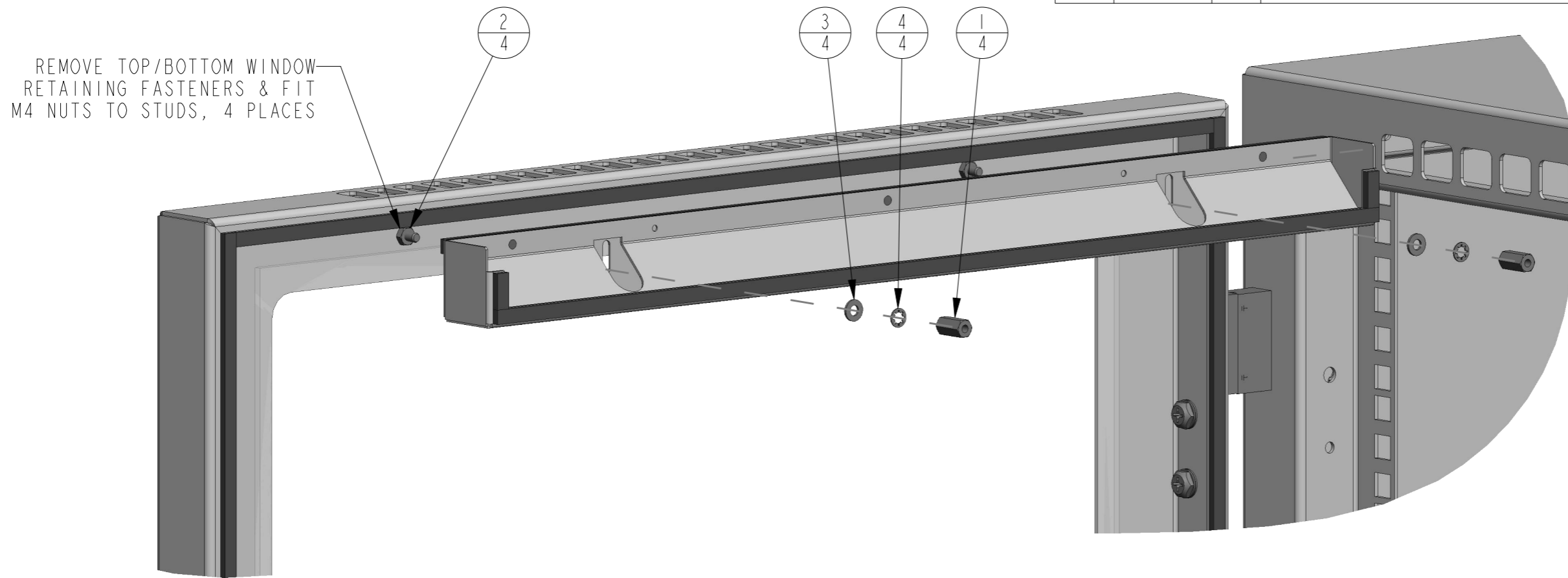

EXPLODED VIEW SHOWING BAFFLE MOUNTING IN CABINET
SCALE 0.500

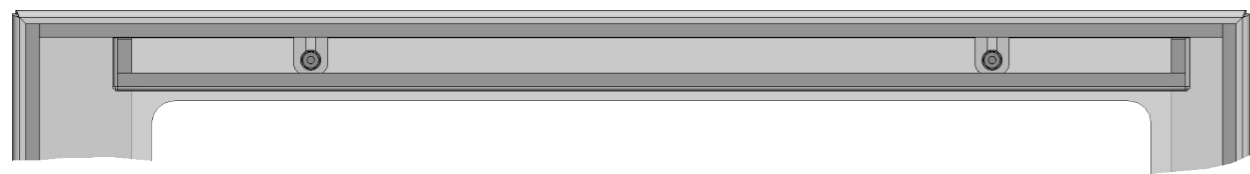

DETAIL A
SHOWING DOOR BAFFLES FITTED
SCALE 0.300

- NOTES:
1. ALL FASTENERS SUPPLIED WITH DOOR BAFFLE ME0621.
 2. BOTTOM BAFFLE MOUNTING IN THE SAME WAY AS THE TOP BAFFLE.
 3. BEFORE TIGHTENING M4 BARREL NUTS PUSH BAFFLES UNDER FOLDS OF DOOR AS SHOWN IN DETAIL A.

CONFIDENTIAL. THIS DOCUMENT MUST NOT BE COPIED NOR THE CONTENTS PASSED ON TO ANY THIRD PARTY WITHOUT THE CONSENT OF THE COMPANY.

UNLESS OTHERWISE STATED: ALL DIMENSIONS IN MILLIMETRES. DO NOT SCALE. TOLERANCES ARE TO BE: 1 DECIMAL PLACE ±0.5, 2 DECIMAL PLACES ±0.3, 3 DECIMAL PLACES ±0.1

3rd ANGLE PROJECTION

ISS/REV	AMENDMENTS	ECO	DRN	CHKD	AUTH	APVD	DATE
A	ORIGINAL	5245	KJS	LSC	MH	DC	02-12-19

© 2019 Johnson Controls. All rights reserved. All specifications and other information shown were current as of document revision date and are subject to change without notice.

JOHNSON CONTROLS
17 MARY MULLER DRIVE
P.O. BOX 19545
CHRISTCHURCH, PH: +64 3 3895096
NEW ZEALAND. FAX: +64 3 3895938

QE20 CABINET COOLING DOOR BAFFLE MOUNTING DETAILS		
DRAWING No: 1919-133		SHEET 2 of 5
A3	ISS/REV A	PART No: ME0623

ITEM	PART NO.	QTY	DESCRIPTION
1	SC0215	2	SCREW, MACHINE, HEX POZI, M5x12, SPRING & FLAT WASHER

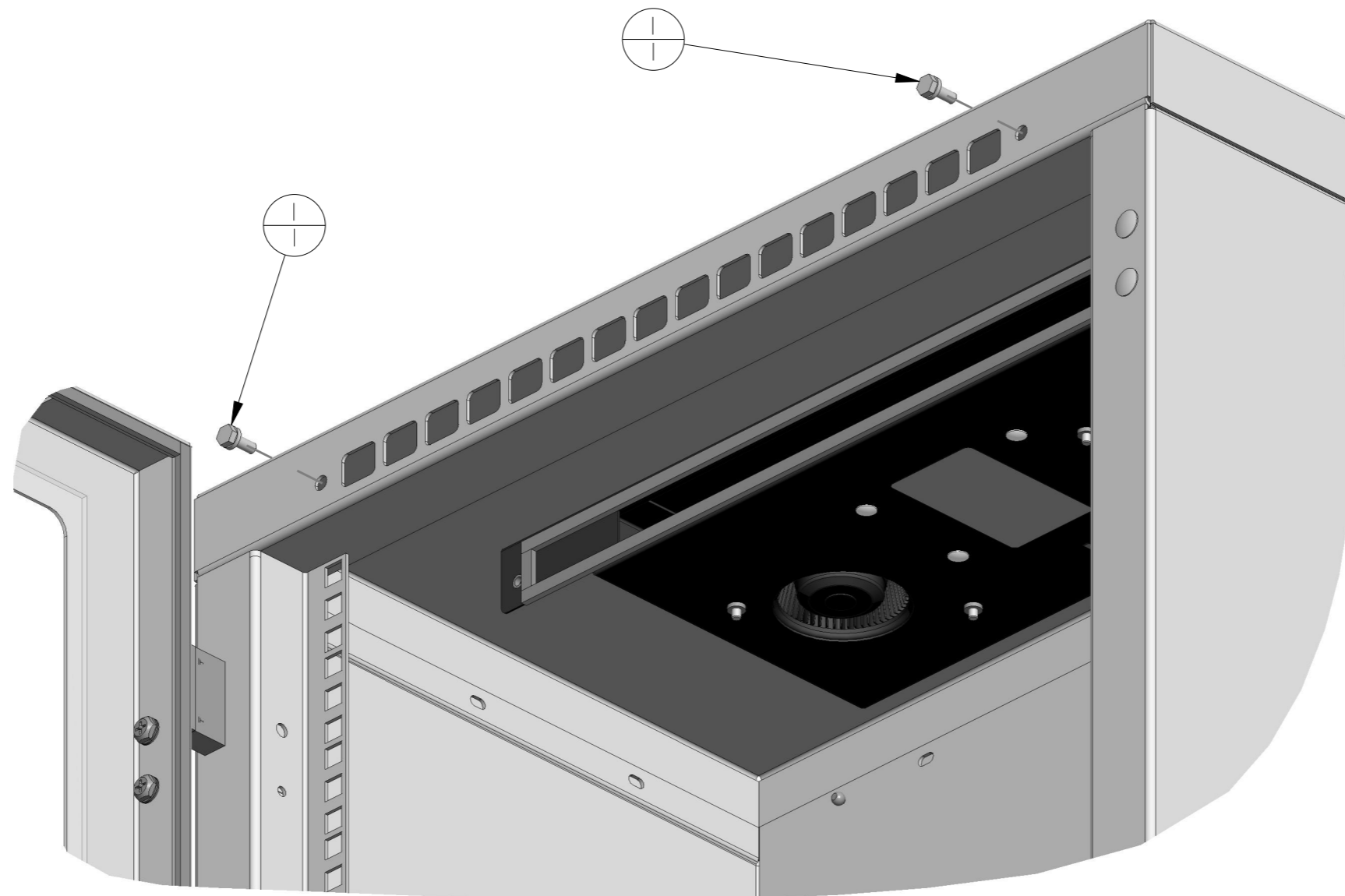

EXPLODED VIEW SHOWING
COOLING MODULE MOUNTING IN CABINET
SCALE 0.400

- NOTES:
1. MODULE MOUNTING FASTENERS SUPPLIED WITH FAN MODULE ME0620.
 2. FAN MODULE WILL SIT IN PLACE WITHOUT BEING HELD WHILE SCREWS ARE FITTED.

CONFIDENTIAL. THIS DOCUMENT MUST NOT BE COPIED NOR THE CONTENTS PASSED ON TO ANY THIRD PARTY WITHOUT THE CONSENT OF THE COMPANY.

UNLESS OTHERWISE STATED: ALL DIMENSIONS IN MILLIMETRES. DO NOT SCALE. TOLERANCES ARE TO BE: 1 DECIMAL PLACE ± 0.5 , 2 DECIMAL PLACES ± 0.3 , 3 DECIMAL PLACES ± 0.1

3rd ANGLE PROJECTION

ISS/REV	AMENDMENTS	ECO	DRN	CHKD	AUTH	APVD	DATE
A	ORIGINAL	5245	KJS	LSC	MH	DC	02-12-19

© 2020 Johnson Controls. All rights reserved.
All specifications and other information shown were current as of document revision date and are subject to change without notice.

JOHNSON CONTROLS
17 MARY MULLER DRIVE
P.O. BOX 19545
CHRISTCHURCH, PH: +64 3 3895096
NEW ZEALAND. FAX: +64 3 3895938

**QE20 CABINET COOLING
FAN MODULE
MOUNTING DETAILS**

DRAWING No: **1919-133** SHEET **3** of **5**

A3 | ISS/REV **A** | PART No: **ME0623**

ITEM	PART NO.	QTY	DESCRIPTION
1	SC0215	2	SCREW, MACHINE, HEX POZI, M5x12, SPRING & FLAT WASHER

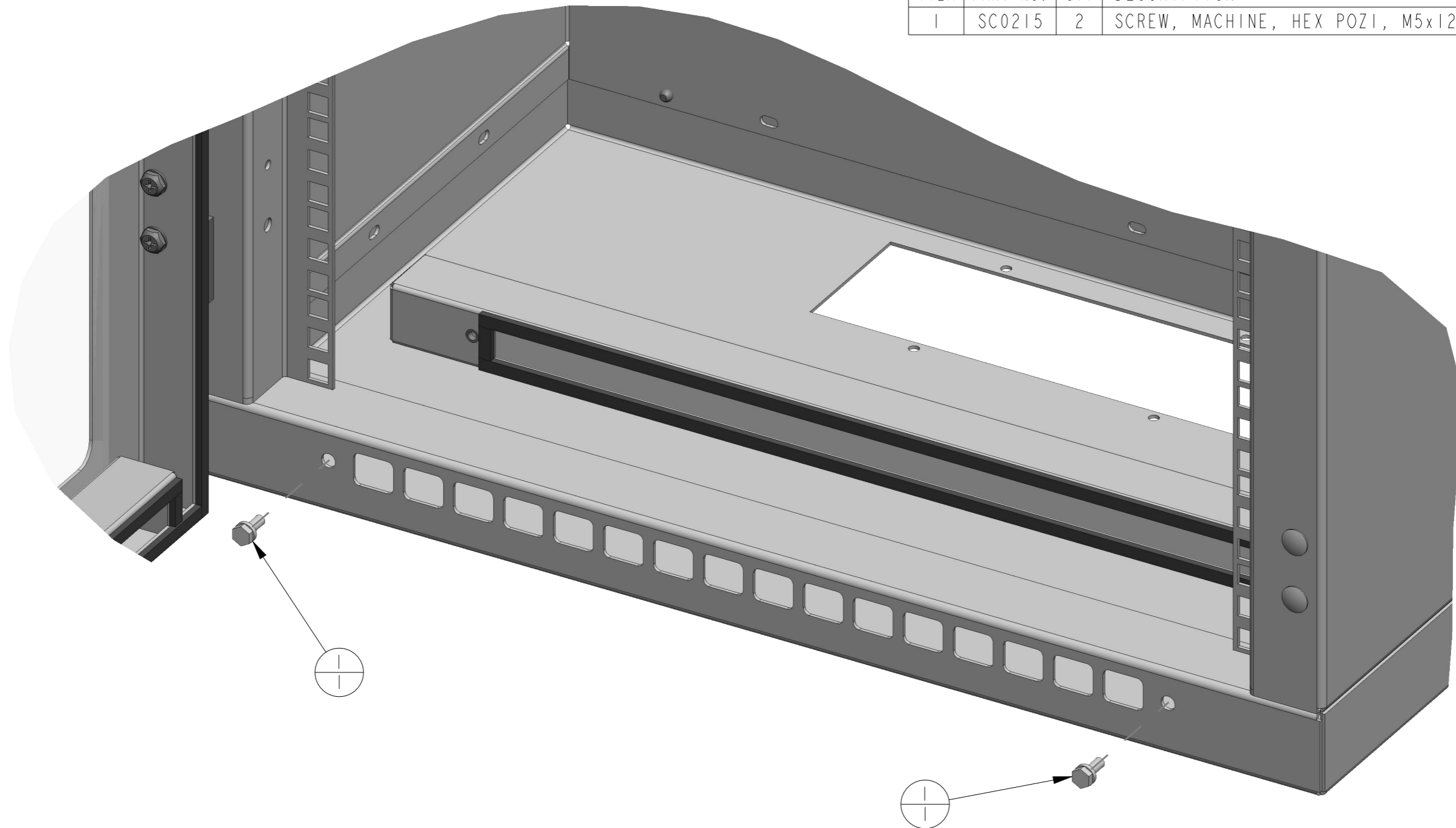

EXPLODED VIEW SHOWING
AIR FILTER MODULE MOUNTING IN CABINET
SCALE 0.500

CONFIDENTIAL. THIS DOCUMENT MUST NOT BE COPIED NOR THE CONTENTS PASSED ON TO ANY THIRD PARTY WITHOUT THE CONSENT OF THE COMPANY.

UNLESS OTHERWISE STATED: ALL DIMENSIONS IN MILLIMETRES. DO NOT SCALE. TOLERANCES ARE TO BE: 1 DECIMAL PLACE ± 0.5 , 2 DECIMAL PLACES ± 0.3 , 3 DECIMAL PLACES ± 0.1

3rd ANGLE PROJECTION

ISS/REV	AMENDMENTS	ECO	DRN	CHKD	AUTH	APVD	DATE
A	ORIGINAL	5245	KJS	LSC	MH	DC	02-12-19

© 2019 Johnson Controls. All rights reserved.
All specifications and other information shown were current as of document revision date and are subject to change without notice.

JOHNSON CONTROLS
17 MARY MULLER DRIVE
P.O. BOX 19545
CHRISTCHURCH, PH: +64 3 3895096
NEW ZEALAND. FAX: +64 3 3895938

**QE20 CABINET COOLING
AIR FILTER MODULE
MOUNTING DETAILS**

DRAWING No: **1919-133** SHEET 4 of 5

A3 | ISS/REV **A** | PART No: **ME0623**

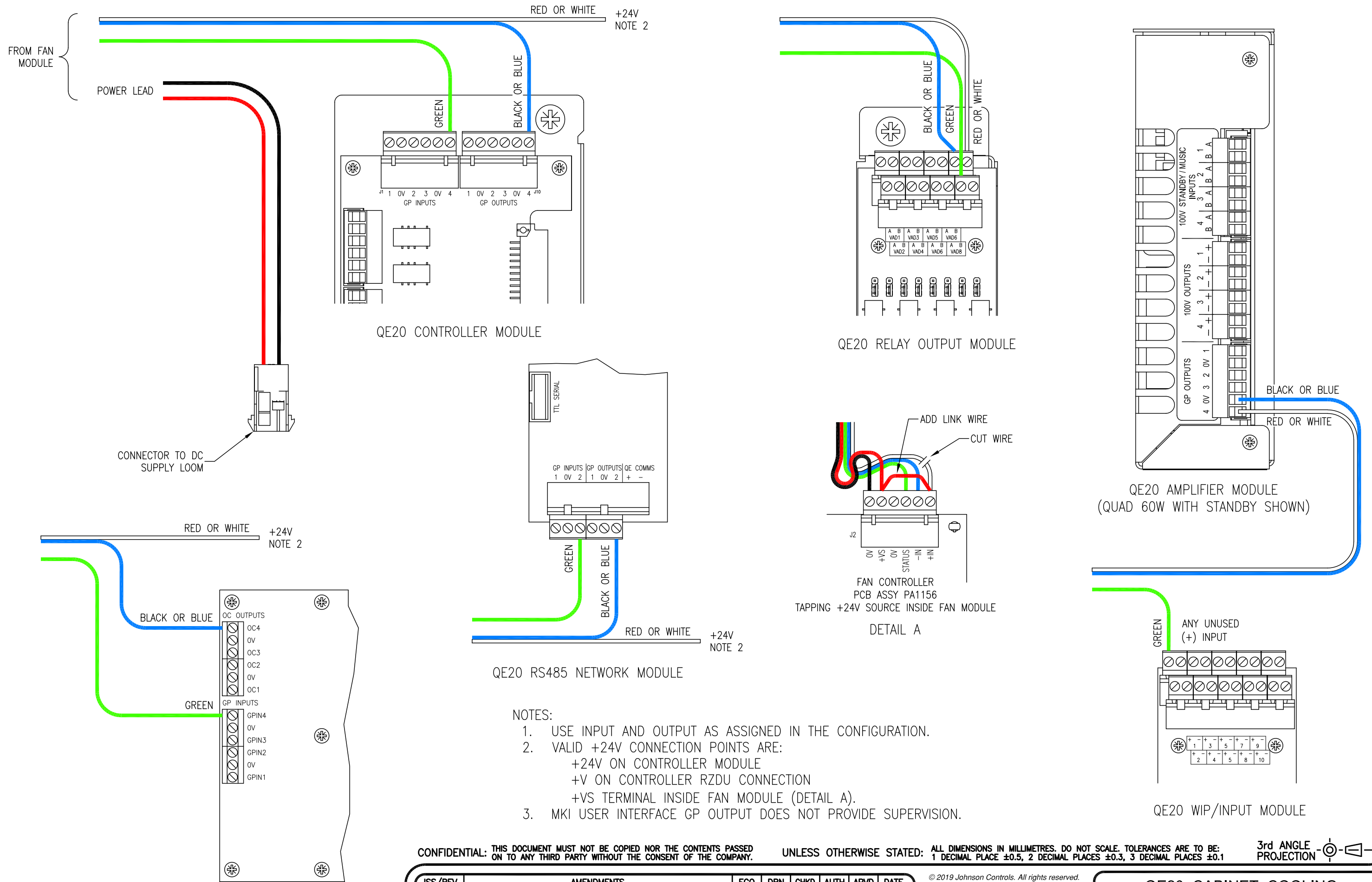

- NOTES:
1. USE INPUT AND OUTPUT AS ASSIGNED IN THE CONFIGURATION.
 2. VALID +24V CONNECTION POINTS ARE:
 +24V ON CONTROLLER MODULE
 +V ON CONTROLLER RZDU CONNECTION
 +VS TERMINAL INSIDE FAN MODULE (DETAIL A).
 3. MKI USER INTERFACE GP OUTPUT DOES NOT PROVIDE SUPERVISION.

CONFIDENTIAL: THIS DOCUMENT MUST NOT BE COPIED NOR THE CONTENTS PASSED ON TO ANY THIRD PARTY WITHOUT THE CONSENT OF THE COMPANY. UNLESS OTHERWISE STATED: ALL DIMENSIONS IN MILLIMETRES. DO NOT SCALE. TOLERANCES ARE TO BE: 1 DECIMAL PLACE ±0.5, 2 DECIMAL PLACES ±0.3, 3 DECIMAL PLACES ±0.1 3rd ANGLE PROJECTION

QE20 UI MKI BOARD
NOTE 3

ISS/REV	AMENDMENTS	ECO	DRN	CHKD	AUTH	APVD	DATE
A	ORIGINAL	5245	KJS	LSC	MH	DC	3-12-19
B	WIRING UPDATED. WIRING TO OTHER MODULES ADDED.	5585	KJS	LSC	MH	DC	20-12-22

© 2019 Johnson Controls. All rights reserved. All specifications and other information shown were current as of document revision date and are subject to change without notice.

JOHNSON CONTROLS
 17 MARY MULLER DRIVE
 P.O. BOX 19545
 CHRISTCHURCH, PH: +64 3 3895096
 NEW ZEALAND. FAX: +64 3 3895938

**QE20 CABINET COOLING
FAN MODULE
WIRING DIAGRAM**

DRAWING No: 1919-133 SHEET 5 of 5

A2	ISS/REV	B	PART No: ME0623
----	---------	---	-----------------